

# ELECTRIC SKATEBOARD

Mr. Vasudev Gurunath Parab<sup>1</sup>, Ms. Tanuja Laxman Kharat<sup>2</sup>, Mr. Kunal Krushna Konduskar<sup>3</sup>,  
Mr. Prathamesh Shashikant Patekar<sup>4</sup>, Mr. Ravindra Ramesh Parab<sup>5</sup>, Mrs. N.S. Malkar<sup>6</sup>

<sup>1,2,3,4,5</sup> Student Yashwantrao Bhonsale Institute Of Technology, Sawantwadi

<sup>6</sup> faculty, Yashwantrao Bhonsale Institute of Technology, Sawantwadi

<sup>1</sup>[rajpatekar53@gmail.com](mailto:rajpatekar53@gmail.com), <sup>2</sup>[kharattanuja75@gmail.com](mailto:kharattanuja75@gmail.com), <sup>3</sup>[kunalkonduskar2008@gmail.com](mailto:kunalkonduskar2008@gmail.com)

## Abstract:

Designed for short-distance travel, the Electric Skateboard with Handle is a small and environmentally friendly personal transportation device. The primary driving component of this project is a DC gear motor, which can smoothly and safely support the rider's weight due to its high torque at low speed. The motor is powered by a rechargeable battery and is attached to the back wheel via a chain or belt driving mechanism. Direction and speed are controlled by a throttle control system and motor driver.

For improved balance, stability, and rider control—especially for novices—the handle is linked to the skateboard frame. Compared to a typical DC motor, the gear motor guarantees better performance and effective power transmission. Because it runs on electricity, this system uses less gasoline and pollutes the air. The project shows how DC motor control, battery management, and mechanical design may be used practically to provide a portable and affordable electric transportation solution.

**Keywords:** Handle Support System, DC Gear Motor, Rechargeable Battery, Chain Drive Mechanism, Sprocket, Motor Controller, Safety and Stability

## I. INTRODUCTION

The electric skateboard with handle is a cutting-edge personal mobility tool made to offer short-distance, safe, and energy-efficient transportation. This device generates smooth and controlled motion using a brushed DC gear motor that is powered by a rechargeable lithium-ion battery, in contrast to traditional skateboards that rely solely on personal effort. To move the skateboard ahead, the motor transforms electrical energy into mechanical energy, which is then transferred to the back wheels via a chain or belt drive mechanism.

The device has a braking mechanism for safe deceleration and halting as well as a handle-mounted throttle for accurate acceleration control. In order to provide steady speed control, overload protection, and longer motor life, an Electronic Speed Controller (ESC) controls the voltage and current applied to the motor. The skateboard is appropriate for novices, senior citizens, and people who need extra assistance because of its handle structure, which improves rider stability, balance, and safety.

In order to sustain rider weight while preserving portability, the frame is usually composed of sturdy yet lightweight material. In contrast to intricate based systems, the design prioritizes cost-effectiveness, simplicity, and

little maintenance. The skateboard contributes to environmentally friendly transportation because it runs solely on electricity and has no direct emissions.

The electric skateboard with handle is a useful tool for short leisure trips, campus mobility, and daily commuting due to its lightweight design, smooth operation, safety measures, and easy-to-use control system.

## II. LITERATURE SURVEY

Enhancing affordability, safety, portability, and efficiency are the main goals of current research in personal electric mobility systems. Handle-supported electric skateboards are designed to improve rider control and balance, making them appropriate for urban settings, campuses, and short-distance transit.

### 1. Electric Drive System:

DC motors or Brushless DC (BLDC) motors are frequently used to propel electric skateboards. Because of its straightforward design, high starting torque, and simple speed control, brushed DC gear motors are favoured in low-cost prototypes [1]. Applications for small electric vehicles frequently use motors like MY1016Z3.

### 2. Techniques for motor control:

Motor controllers based on pulse width modulation (PWM) are used to effectively control speed. Electronic speed controllers (ESCs) shield the motor from overload situations and enhance smooth acceleration [2].

### 3. Battery & Energy Storage Systems:

Due to its high energy density, lightweight design, and extended lifespan, lithium-ion batteries are widely employed. Compact electric mobility devices can run on a 24V battery system [3].

### 4. Mechanical Transmission System:

Motor power is transferred to the wheels using belt drive mechanisms or chain and sprocket systems. Systems for gear reduction increase climbing capabilities and torque [4].

### 5. Safety and Control Mechanisms:

Handle support structures, brake systems, and throttle handles enhance rider stability and safety. Protective fuses and battery management systems (BMS) are also features of contemporary systems [5].

## 6. Applications:

Because of their small size and environmentally benign operation, electric skateboards with handle support are utilized for short-distance transportation, educational campuses, industrial locations, and recreational purposes.

## III. METHODOLOGY

The Electric Skateboard with Handle was developed using a methodical, step-by-step process to guarantee correct performance, safety, and design.

### 1. Analysis and Planning of Requirements

The project's initial needs, such as load capacity, speed range, battery voltage, and safety measures, were determined. The rider's weight was intended to be supported by the design while preserving mobility and stability. Based on an appropriate DC gear motor was chosen. the required RPM and torque rating,

### 2. Selection of Components

Every component that was required was carefully chosen to guarantee efficiency and compatibility. The primary elements consist of:

- DC gear motor (low RPM, high torque)
- Depending on the design, a rechargeable battery
- A motor controller or driver
- PWM speed control unit or throttle
- A belt or chain driving system
- Skateboard deck and wheels
- A handle and frame made of metal
- Wiring, switches, and safety

All electrical components were chosen with the voltage and current ratings necessary for safe operation in mind.

**3. Design and Assembly of Mechanical Systems** A sturdy and lightweight frame was used in the construction of the mechanical structure. To guarantee correct alignment, the DC gear motor was firmly installed next to the back tire. For effective power transfer, a chain or belt drive mechanism was put in place between the motor shaft and the back wheel. To improve balance and control, the handle was securely fastened to the front of the skateboard. To prevent vibrations and mechanical losses, proper fastening and alignment were made sure of.

**4. Implementation of Electrical Circuits** The motor driver, which manages the DC gear motor, was linked to the battery. To smoothly adjust speed, a PWM controller or throttle mechanism was incorporated. To avoid short circuits, appropriate wire management, insulation, and connectors were used. For increased safety against overcurrent situations, a fuse or circuit breaker was installed.

**5. Evaluation of Performance and Testing** The skateboard was put together and tested under various load scenarios. We looked examined the battery backup time, torque performance, speed, and acceleration. Additionally, braking performance and stability were examined. The necessary changes were implemented to increase effectiveness and security.

### 6. Safety Procedures and Enhancement

By guaranteeing steady handle support, an appropriate braking system, and a smooth engine response, extra care was taken to ensure rider safety. In order to lower energy usage and extend battery life, the system was adjusted.

**7. Concluding Documentation and Analysis** Lastly, the system's overall effectiveness, performance, benefits, and drawbacks were examined. The outcomes were recorded to assess whether the project's goals

## IV. OBJECTIVES

- To create an electric skateboard for short-distance mobility that is driven by a DC gear motor.
- To offer a sustainable mobility option that lowers air pollution and fuel consumption.
- To ensure stable and smooth movement, a DC gear motor is used to achieve high torque at low speed.
- To put in place a motor driver and throttle mechanism for safe acceleration and deceleration as part of a speed control system.
- Adding a strong handle to the skateboard's frame will increase rider safety and balance.
- The goal is to create a lightweight, portable, and user-friendly design.
- To comprehend how battery management, mechanical power transfer, and electric drive systems are used in real-world situations.
- To develop a personal transportation system that is both economical and useful for short journeys and campuses.

## V. WORKING

The Electric Skateboard with Handle operates by utilizing a DC gear motor to transform electrical energy into mechanical energy. The motor driver (controller) is powered by the rechargeable battery when the main switch is turned on. The motor driver receives a signal from the throttle, also known as the thumb accelerator or twist grip, to regulate speed.

The motor driver gives the DC gear motor extra voltage and current as the rider increases the throttle. Electrical energy is transformed into mechanical rotational energy by the motor as it begins to rotate. The built-in gearbox helps to smoothly start and carry

the rider's weight without jerks by increasing torque and decreasing speed.

A chain drive or belt drive connects the motor shaft to the back wheel. The skateboard moves ahead as a result of torque being transferred to the back wheel by the rotating motor. The throttle position affects the skateboard's speed.

- Acceleration: Speed is increased by turning the throttle
- Constant Speed: Steady motion is maintained by holding down the throttle.
- Deceleration: The skateboard slows down when the throttle is reduced.
- Braking: The skateboard is stopped by applying the brake or releasing the throttle.

Particularly when braking and turning, the handle improves control, balance, and stability. All components of the system—wheels, handle, transmission system, motor driver, battery, and DC gear motor—work together to deliver regulated and seamless movement.

## VI. COMPONENT USED

- 24V Lithium-ion Battery
- 24V Battery Charger
- Main Power Switch
- Motor Controller (24V, 250W)
- DC Gear Motor (24V, 250W);
- Hall Effect Type Throttle Handle
- Wheels

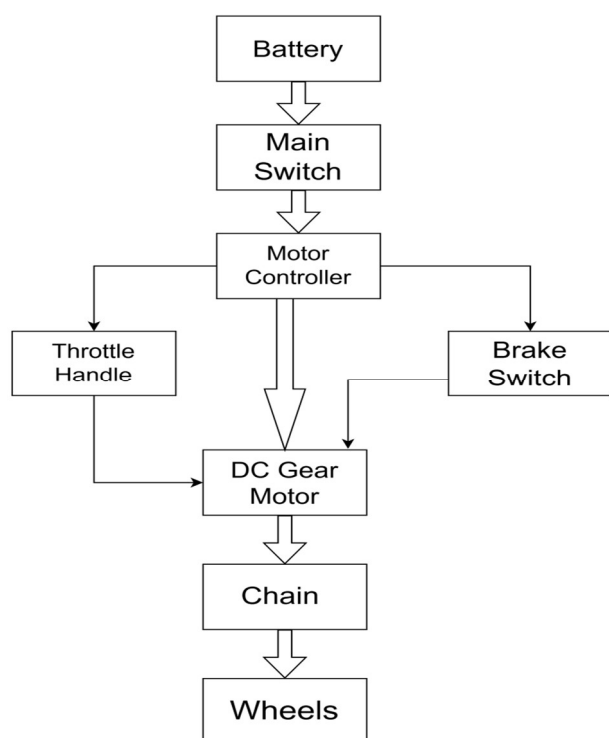

Fig. 1: Block diagram of Electric Skateboard

## VII. CONCLUSION

A 24V battery, motor controller, and DC gear motor were used in the successful design and development of the electric skateboard with handle. To effectively move the wheels, the mechanism transforms electrical energy into mechanical energy. A DC gear motor with strong torque and steady performance, such as the MY1016Z3, is appropriate for regulated and fluid motion.

Easy speed control is made possible by the throttle handle, and rider safety and balance are enhanced by the handle structure. This project serves as an example of a short-distance, economical, and energy-efficient kind of transportation. All things considered, the technology works well as a personal mobility solution.

## VIII. REFERENCES

- [1] "Adaptive Control of Electric Skateboard," U.S. Patent 12,403,385, Sept. 2, 2025.
- [2] In the International Journal for Multidisciplinary Research (IJFMR), volume 7, issue 1, pages 1–10, January–February 2025, [2] "Electric Skateboard Motor & Battery Calculations."
- [3] "High-Performance Driver Design for BLDC Motors in Light Electric Vehicles," in ELECO 2025 International Conference Proceedings, November 27–29, 2025.
- [4] Kumar, A., and Li, J. (2024). A review of the design and control of portable electric mobility devices. 16(2), 182–198, International Journal of Electric and Hybrid Vehicles.
- [5] Performance Analysis of DC Gear Motors in Personal Electric Vehicles, Singh, R., & Patel, S. (2023). 12(4), 45–55; Journal of Automotive Engineering and Technology.
- [6] Lee, T., and Zhang, Y. (2022). Strategies for Improving Electric Skateboard Energy Efficiency. 9350–9360 in IEEE Transactions on Vehicular Technology, 71(8).
- [7] Sharma, P., and Gupta, M. (2021). DC motor speed control using PWM methods. IJEET, 12(1), 10–17; International Journal of Electrical Engineering & Technology.
- [8] Banerjee, S., and Dutta, A. (2020). Design of an Electric Skateboard with Improved Stability Features. 9(3), 23–29; Asian Journal of Engineering and Applied Technology.
- [9] N. Bhattacharya (2019). principles of gear motor applications and DC motors. Drives and Power

Electronics, 5(1), 66–77.

[10] Miller, T., and Hendershot, J. (2018). Brushless Permanent-Magnet Motor Design, Third Edition. Newnes. (Helpful for comprehending torque calculations and motor selection.)